



**ACECO**  
PRECISION



## COMMITMENT TO QUALITY.

For 55 years AceCo has been dedicated to manufacturing the highest quality tools. AceCo's commitment to quality results in our success and a high level of confidence from our customers.

## PRECISION

Investment in advanced technology, inspection methods and a highly skilled work force ensures accuracy and repeatability in every part we make.

## CONFIDENCE

Traceability of all AceCo products include information about the raw material vendor, metallurgical chemistry, heat treatment reports and inspection documentation. All AceCo parts are serialized allowing all manufacturing details to be reviewed. We stand behind every part we make.

## WORLD CLASS SERVICE & SUPPORT

We pride ourselves on unmatched customer service and superior technical support. Our engineering department and technical sales staff can assist you in resolving your production and product quality issues.

MADE IN  
USA

ACECO  
MANUFACTURING  
BOLSE, ID USA  
C16-032  
LOT=026289

## FINGER JOINT TOOLS

- Finger Joint Tooling Solutions 3
- Types of Finger Joints 5
- Finger Joint Length Examples 6
- ACE Finger Joint Heads 7-10
- ACE Finger Joint Cutters 11-13
- Evolution 3 Finger Joint Cutters 14

## MOULDER TOOLS

- Moulder Tooling Solutions 15
- Ace-Loc Moulder Heads 17-18
- Shear Cut Ace-Loc Moulder Heads 19
- HSK Moulder Heads 20
- Straight Bore Moulder Heads 20

## PLANER TOOLS

- Planer Tooling Solutions 21
- Planer Head Features 23
- Straight Knife Planer Heads 24
- L Knife Planer Heads 25
- L-V Knife Planer Heads 26

## HYDRAULIC CARTRIDGES

- Ace-Loc Hydraulic Tool Holders 28
- Ace-Loc Hydraulic Saw Holders 30

## ACCESSORIES

- Finger Joint Accessories 31
- Moulder & Planer Accessories 32
- Hydraulic & Grease Gun Accessories 32

## CUSTOM TOOLS

- Custom & Special Applications 33

# FINGER JOINT TOOLS





# TYPES OF FINGER JOINTS

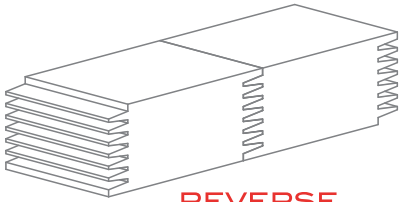

REVERSE

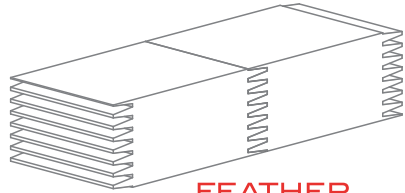

FEATHER

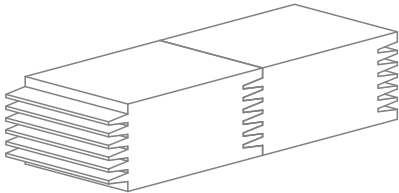

MALE-FEMALE

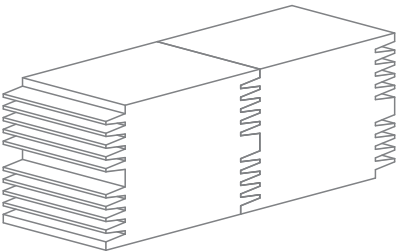

REVERSE RESAW

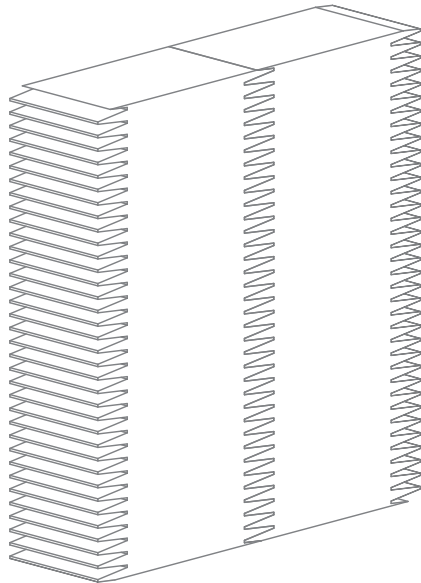

VERTICAL FEATHER

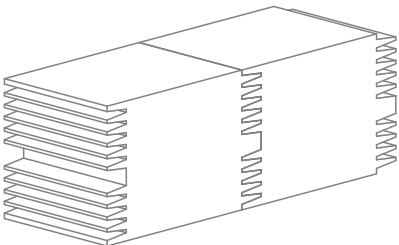

MALE-FEMALE RESAW

# FINGER JOINT LENGTH EXAMPLES

## NON-STRUCTURAL

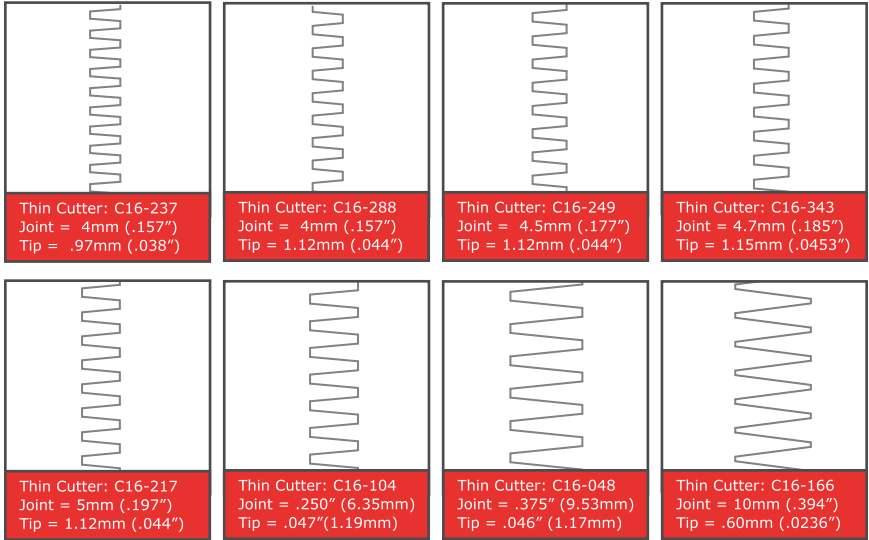

## SUB-STRUCTURAL

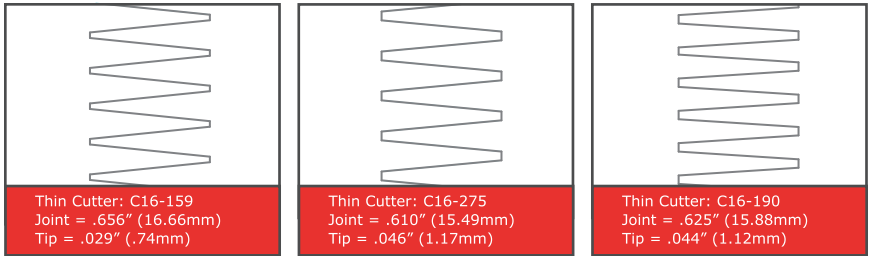

## STRUCTURAL

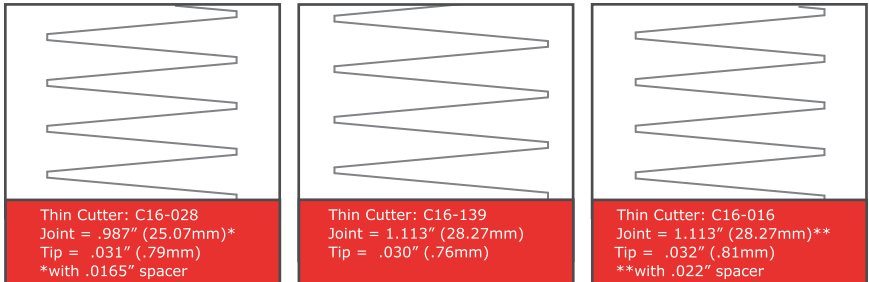

# FINGER JOINT HEADS



## ACE-LOC HEADS

Ace-Loc finger joint heads represent the most accurate advancement in hydraulic, self-centering cutter heads. Ace-Loc finger joint heads offer longer cutter life, more accurate cuts, and quicker tool changes.

### BEST USES

- High Speed
- High Production
- All Joint Lengths
- 180mm to 19.000" Extreme Swing
- Horizontal Joints

### BENEFITS

- Uses Standard AceCo Cutters
- High Precision
- Durability
- Low Maintenance
- Long Cutter Life



## CLASS II PREMIUM HEADS

Class II heads ensure the most accurate finger joints possible. The bottom plate (knife face) is guaranteed to be within .0005" (.0125 mm) perpendicularity to the bore.

### BEST USES

- High Speed
- High Production
- Micro-joints (5mm and shorter)
- 9.000" to 10.500" Extreme Swing
- Horizontal Joints

### BENEFITS

- Uses Standard AceCo Cutters
- High Precision
- Durability
- Low Maintenance
- Long Cutter Life

# FINGER JOINT HEADS

## TURBO HEADS

The same great features as our Ace-Loc heads, but specifically designed to work on European style machines.

### BEST USES

- True 8 Wing or Staggered Setup
- 250mm Cut Circle
- Vertical Joints up to 150mm material.
- Low Maintenance

### BENEFITS

- Uses Standard Cutters
- Durability
- Long Cutter Life
- Low Maintenance

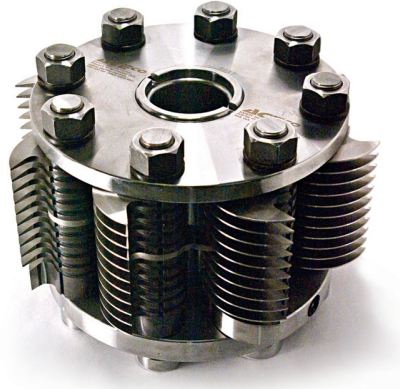

## STACKABLE FJ SYSTEM

The solution for very tall finger joints and custom applications.

### BEST USES

- Moderate Speed
- Tall Vertical Stacks

### BENEFITS

- Uses Standard Cutters
- Durability
- Long Cutter Life
- Low Maintenance

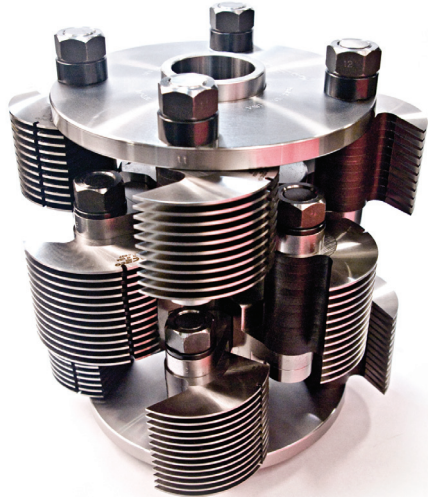

## COLLET / STRAIGHT BORE HEADS

### BEST USES

- Low Production Runs
- Machines that cannot fit hydraulically-centered heads.

### BENEFITS

- Uses Standard Cutters
- Economical
- Reliable
- Low Maintenance



# FINGER JOINT HEADS

All AceCo finger joint heads are precision machined from hardened alloy steel to resist the daily abuse of an industrial millwork operation. AceCo's heads are known to run smoother and last longer than any other finger joint head made. From 4 to 20 bolts, AceCo offers the widest selection of standard and custom finger joint heads to fit most finger jointing machines.



**HIGH TENSILE ALLOY STEEL**  
4150 Heat-treated steel for maximum durability and performance.

**HARDENED STEEL NUTS**  
Grade 8 - High Strength

**HARDENED STEEL BOLTS**  
High Strength / Precision Machined



**PLUNGER STYLE GREASE ZERKS**  
The plunger style is cleaner and more reliable than a check ball.

**HYDRAULIC CENTERING**  
Ace-Loc hydraulic sleeves ensure repeatability, accuracy, and balance. Heat-treated sleeves are available for keyed spindles.

**CLASS II OPTION**  
.0005" Bore to Bottom Plate (knife face) perpendicularity.



**7200 RPM BALANCING**  
Precision balanced on a computer-aided dynamic balancer to ISO Grade G-1.0, far beyond industry standards.

# FINGER JOINT HEADS

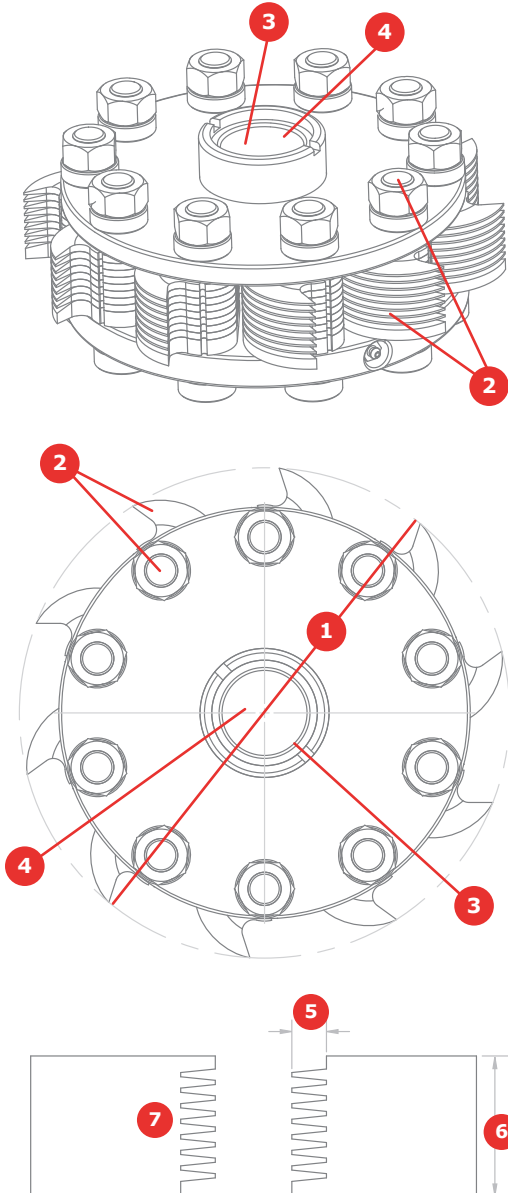

To order or request a quote, please specify the following:

<b>1</b>	<b>EXTREME SWING (Cutting Circle)</b> <ul style="list-style-type: none"> <li>• Diameter across head from cutting tip to tip.</li> </ul>
<b>2</b>	<b>NUMBER OF BOLTS (or WINGS)</b> <ul style="list-style-type: none"> <li>• 4 Knife</li> <li>• 6 Knife</li> <li>• 8 Knife</li> <li>• 10 Knife</li> <li>• Custom Size</li> </ul>
<b>3</b>	<b>SPINDLE DIAMETER</b> <ul style="list-style-type: none"> <li>• 1.500"</li> <li>• 1.813"</li> <li>• 50mm</li> <li>• 2.125"</li> <li>• Custom Size</li> </ul>
<b>4</b>	<b>CENTERING TYPE</b> <ul style="list-style-type: none"> <li>• Ace-Loc Hydraulic*</li> <li>• Straight Bore</li> <li>• Collet</li> </ul>
<b>5</b>	<b>JOINT LENGTH</b>
<b>6</b>	<b>MATERIAL THICKNESS</b>
<b>7</b>	<b>JOINT TYPE</b> (see page 6) <ul style="list-style-type: none"> <li>• Reverse</li> <li>• Male / Female</li> <li>• Feather</li> <li>• Other</li> </ul>
<b>8</b>	<b>MACHINE INFORMATION</b> <ul style="list-style-type: none"> <li>• Make /Model</li> <li>• Number of Spindles</li> <li>• R.P.M.</li> <li>• Feed Rate</li> <li>• Lug or Packet Style</li> <li>• Trim Saw: Yes or No</li> </ul>
<i>Additional Options:</i> *Heat Treated Sleeves for Keyed Spindles	

# FINGER JOINT CUTTERS

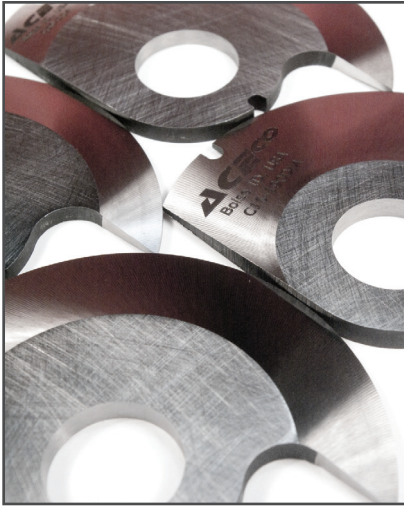

AceCo finger joint cutters are the ultimate in quality and cutting precision. Our cutters are manufactured using American Iron and Steel Institute (AISI) rolled and billet stock M2 tool steel, hardened and ground to specific dimensional tolerances of  $\pm .0001$  of an inch (.0025 mm). Using advanced statistical process control and inspection procedures produces the highest quality cutters on the market today.

## FINITE FINISH™

*Finite Finish™* is a combination of **thickness accuracy** and **flatness**. This process is what makes our finger joint cutters the best in the world. Cutters compress better, have tighter tolerances, and produce more consistently accurate joints.

### THICKNESS ACCURACY

*Finite Finish™* guarantees thickness accuracy tolerances to be held to under  $\pm .0001$ " or  $\pm .0025$ mm. *Finite Finish™* eliminates tolerance accumulation problems associated with stacked cutters.

### FLATNESS

Flatness tolerances below  $.00005$ " (50 millionths of an inch) (.0012mm).



## ADVANTAGES OF THE CIRCLE BIT CUTTER DESIGN:

The life cycle of the circle bit cutter design is what makes it superior. As illustrated below, this C16-217 cutter has a useable life arc of 3.767". Most importantly the cutter geometry remains unchanged because it is rotated forward and "reset" on the head as face material is removed during grinding. Another benefit is that each cutter is individually replaceable within a cutter stack; meaning a cutter with a broken tip can be replaced without effecting the other cutters in the head.

**USEABLE LIFE ARC**  
**3.767" (95.68mm)**

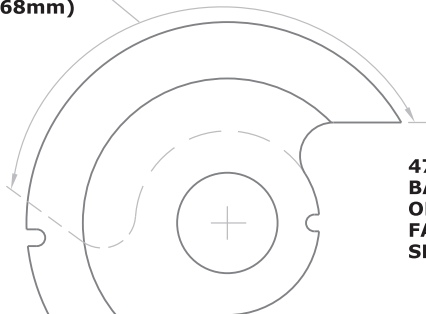

**471 SHARPENINGS**  
**BASED ON REMOVAL**  
**OF .008" (.20mm)**  
**FACE MATERIAL PER**  
**SHARPENING**

# CUTTER TERMINOLOGY

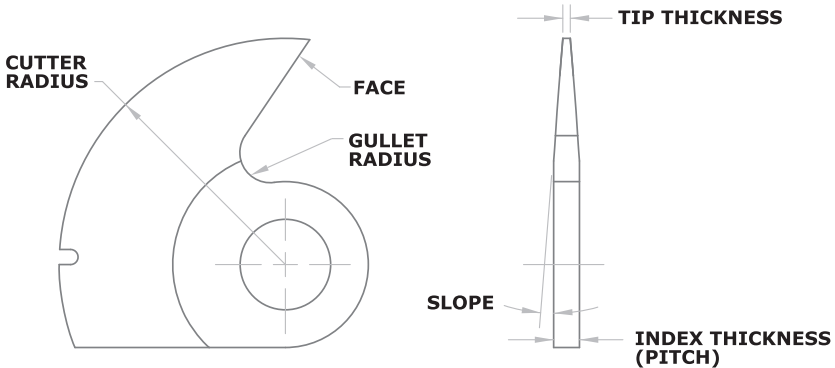

## HSS STANDARD FINGER JOINT CUTTERS

AceCo Part#	Joint Length	Cutter Thickness	Cutter Radius	Cutter Tip	Hook Gauge
<b>C16-007</b>	1.113" (28.27mm)*	.2480" (6.30mm)	2.125" (53.98mm)	.0300" (.76mm)	G17-022
<b>C16-008</b>	1.113" (28.27mm)*	.5600" (14.22mm)	2.125" (53.98mm)	.3420" (8.69mm)	G17-022
<b>C16-016</b>	1.113" (28.27mm)**	.2430" (6.17mm)	2.375" (60.33mm)	.0320" (.81mm)	G17-023
<b>C16-017</b>	1.113" (28.27mm)**	.4940" (12.55mm)	2.375" (60.33mm)	.2830" (7.19mm)	G17-023
<b>C16-028</b>	.987" (25.07mm)***	.2225" (5.65mm)	1.875" (47.63mm)	.0310" (.79mm)	G17-021
<b>C16-029</b>	.987" (25.07mm)***	.5515" (14.0mm)	1.875" (47.63mm)	.3600" (9.14mm)	G17-021
<b>C16-032</b>	.625" (15.88mm)	.2140" (5.44mm)	1.875" (47.63mm)	.0620" (1.57mm)	G17-020
<b>C16-033</b>	.625" (15.88mm)	.4950" (12.57mm)	1.875" (47.63mm)	.3430" (8.71mm)	G17-020
<b>C16-048</b>	.375" (9.53mm)	.1685" (4.28mm)	1.500" (38.10mm)	.0460" (1.17mm)	G17-018
<b>C16-049</b>	.375" (9.53mm)*	.3735" (9.49mm)	1.500" (38.10mm)	.2510" (6.38mm)	G17-018
<b>C16-104</b>	.250" (6.35mm)	.1390" (3.53mm)	1.500" (38.10mm)	.0470" (1.19mm)	G17-018
<b>C16-105</b>	.250" (6.35mm)	.3440" (8.74mm)	1.500" (38.10mm)	.2520" (6.40mm)	G17-018
<b>C16-107</b>	1.113" (28.27mm)	.5755" (14.63mm)	2.125" (53.98mm)	.3420" (8.69mm)	G17-022
<b>C16-139</b>	1.113" (28.27mm)	.2635" (6.69mm)	2.125" (53.98mm)	.0300" (.76mm)	G17-022
<b>C16-159</b>	.656" (16.66mm)	.1850" (4.70mm)	1.875" (47.63mm)	.0290" (.74mm)	G17-028
<b>C16-179</b>	.656" (16.66mm)	.3160" (8.03mm)	1.875" (47.63mm)	.1600" (4.06mm)	G17-028
<b>C16-166</b>	10mm (.394")	.1496" (3.80mm)	1.500" (38.10mm)	.0236" (.60mm)	G17-018
<b>C16-167</b>	10mm (.394")	.3560" (9.04mm)	1.500" (38.10mm)	.2300" (5.84mm)	G17-018
<b>C16-168</b>	10mm (.394")	.1496" (3.80mm)	1.250" (31.75mm)	.0236" (.60mm)	G17-024
<b>C16-169</b>	10mm (.394")	.3135" (7.96mm)	1.250" (31.75mm)	.1875" (4.76mm)	G17-024
<b>C16-190</b>	.625" (15.88mm)	.1685" (4.28mm)	1.500" (38.10mm)	.0440" (1.12mm)	G17-019
<b>C16-191</b>	.625" (15.88mm)	.3746" (9.51mm)	1.500" (38.10mm)	.2500" (6.35mm)	G17-019
<b>C16-217</b>	5mm (.197")	.1250" (3.18mm)	1.500" (38.10mm)	.0440" (1.12mm)	G17-018
<b>C16-218</b>	5mm (.197")	.3310" (8.41mm)	1.500" (38.10mm)	.2500" (6.35mm)	G17-018
<b>C16-237</b>	4mm (.157")	.1000" (2.54mm)	1.500" (38.10mm)	.0380" (.96mm)	G17-018
<b>C16-238</b>	4mm (.157")	.3020" (7.67mm)	1.500" (38.10mm)	.2400" (6.10mm)	G17-018
<b>C16-249</b>	4.5mm (.177")	.1210" (3.07mm)	1.500" (38.10mm)	.0440" (1.12mm)	G17-018
<b>C16-250</b>	4.5mm (.177")	.3270" (8.31mm)	1.500" (38.10mm)	.2500" (6.35mm)	G17-018
<b>C16-275</b>	.610" (15.49mm)	.2085" (5.30mm)	1.500" (38.10mm)	.0460" (1.17mm)	G17-019
<b>C16-276</b>	.610" (15.49mm)	.4135" (10.50mm)	1.500" (38.10mm)	.2510" (6.38mm)	G17-019
<b>C16-343</b>	4.7mm (.185")	.1250" (3.18mm)	1.500" (8.10mm)	.0453" (1.15mm)	G17-018
<b>C16-344</b>	4.7mm (.185")	.3310" (8.41mm)	1.500" (38.10mm)	.2513" (6.38mm)	G17-018

- Notes:**
- Cutters are shown with their mating thin and thick pairs.
  - Joint length can vary due to radial runout of tooling and/or spindle.
  - Some cutters are designed to use spacers as noted:
    - \* Joint length with .0155" spacer
    - \*\* Joint length with .022" spacer
    - \*\*\* Joint length with .0165" spacer

# CUTTER MATERIALS & COATINGS

## M2 HSS

- Finite Finish™
- AISI M2 Tool Steel
- Soft Woods To Medium Hard Woods
- See Standard Cutter List On Page 12



## EVOLUTION 3

- High Performance Coating
- Reduced maintenance costs
- AISI M2 Tool Steel
- Finite Finish™
- Dramatically increase run times between sharpening.
- Can be applied to all cutter sizes.
- See Page 14

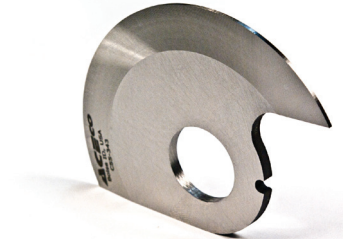

## CARBIDE

- Engineered Materials
- Laminated Veneer Lumber (LVL)
- Lumber With High Silicon Content
- Plywood And Composite Materials
- Exotic Hardwoods
- Materials with abrasive glue lines.
- Finite Finish™
- Solid carbide eliminates need for retipping.

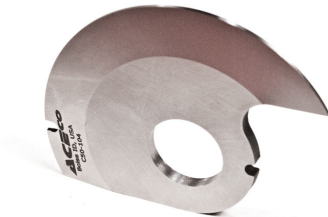

# EVOLUTION 3

**Evolution 3 is a specifically engineered performance coating that is applied by vapor deposition at only .00025" (.0064mm) thickness.**

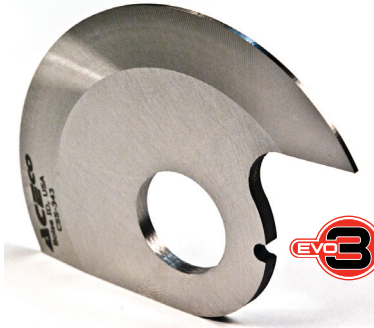

- *Evolution 3* finger joint cutters have the same geometry and tolerances as the standard AceCo M2 HSS cutters.
  - Fiber savings is a major benefit of *Evolution 3*. During production, joint length growth is minimized for a consistent joint geometry and increased material savings.
  - Provides a cutting edge that is harder than tungsten carbide, but without the brittleness.
- Harder than hard chrome plating and with the ability to provide a uniform thickness at the cutting edge, *Evolution 3* cutters retain the true cutting tool geometry. Conversely, chrome (bath) plating forms edge buildup at the corners, not reflective of the true part shape.
  - Can be sharpened using a CBN wheel, no diamond wheel required.
  - Coating can be applied to most cutting tools including knife steel or wear parts.

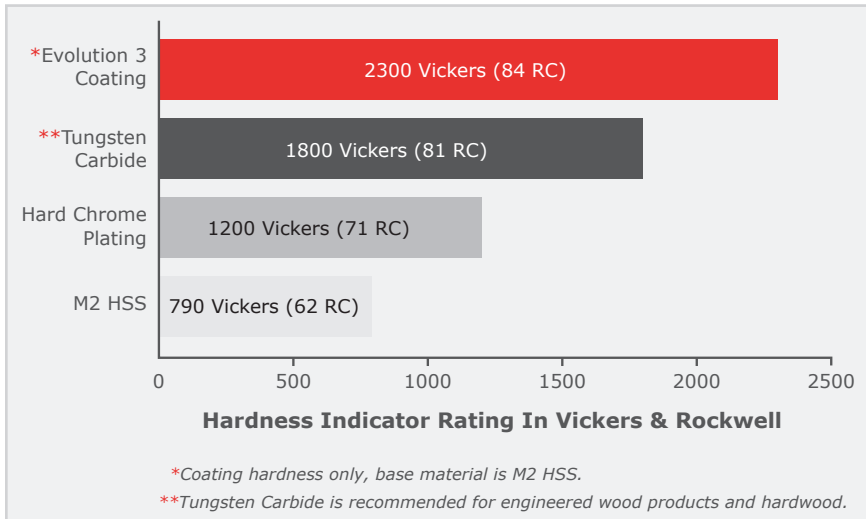

# MOULDER TOOLS





# ACE-LOC HYDRAULIC MOULDER HEADS

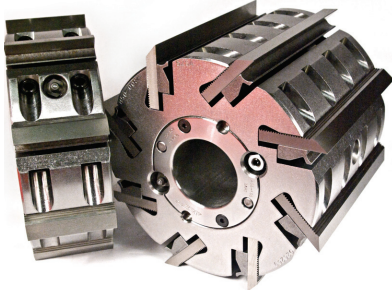

**HIGH TENSILE ALLOY STEEL**  
4150 Heat-treated steel for maximum durability and performance.

**HARDENED RADIUS GIBS:**  
Heat-treated all the way through to resist screw wear; radius design provides better chip flow.

**DEEPER KNIFE POCKETS**  
Allows for use of wider knife steel.

**WIDER KNIFE POCKETS**  
Can accommodate up to 10mm thick knife steel.

**GIB SCREWS**  
Allen head are standard - Square or Hex head are also available.

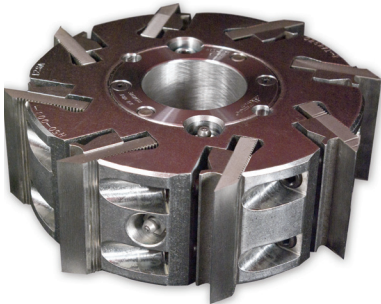

**PLUNGER STYLE  
GREASE ZERKS**  
The plunger style is cleaner and more reliable than a check ball.

**GREASE FITTINGS**  
Located on all end faces. Also located on outside diameters when possible.

**STANDARD CUTTING ANGLES**  
12° or 20° standard cutting angles to handle hard or softwoods.

**KNIFE POCKET OPTIONS**  
16-60° Corrugated or Flat Back.

**7200 RPM BALANCING**  
Precision balanced on a computer-aided dynamic balancer to ISO Grade G-1.0, far beyond industry standards.

**HYDRAULIC CENTERING**  
Ace-Loc hydraulic sleeves ensure repeatability, accuracy, and balance. Heat-treated sleeves are available for keyed spindles.



# ACE-LOC HYDRAULIC MOULDER HEADS

To order or request a quote, please specify the following:

<b>1</b>	<b>BODY DIAMETER</b>	<b>150mm</b>	<b>163mm</b>	<b>195mm</b>
<b>2</b>	<b>NUMBER OF KNIVES</b>	<ul style="list-style-type: none"> <li>• 4 Knife</li> <li>• 6 Knife</li> <li>• 8 Knife</li> </ul>	<ul style="list-style-type: none"> <li>• 6 Knife</li> <li>• 8 Knife</li> <li>• 10 Knife</li> </ul>	<ul style="list-style-type: none"> <li>• 10 Knife</li> <li>• 12 Knife</li> <li>• 14 Knife</li> </ul>
<b>3</b>	<b>BODY WIDTH</b>	<ul style="list-style-type: none"> <li>• 60mm</li> <li>• 76mm</li> <li>• 100mm</li> <li>• 130mm</li> <li>• 150mm</li> <li>• 180mm</li> <li>• 200mm</li> <li>• 230mm</li> <li>• 260mm</li> <li>• 310mm</li> </ul>	<ul style="list-style-type: none"> <li>• 60mm</li> <li>• 76mm</li> <li>• 100mm</li> <li>• 130mm</li> <li>• 150mm</li> <li>• 180mm</li> <li>• 200mm</li> <li>• 230mm</li> <li>• 260mm</li> <li>• 310mm</li> </ul>	<ul style="list-style-type: none"> <li>• 60mm</li> <li>• 76mm</li> <li>• 100mm</li> <li>• 130mm</li> <li>• 150mm</li> <li>• 180mm</li> <li>• 200mm</li> <li>• 230mm</li> <li>• 260mm</li> <li>• 310mm</li> </ul>
<b>4</b>	<b>POCKET STYLE</b>	<ul style="list-style-type: none"> <li>• Corrugated</li> <li>• Flatback</li> </ul>	<ul style="list-style-type: none"> <li>• Corrugated</li> <li>• Flatback</li> </ul>	<ul style="list-style-type: none"> <li>• Corrugated</li> <li>• Flatback</li> </ul>
<b>5</b>	<b>GIB SCREWS</b>	<ul style="list-style-type: none"> <li>• Allen Head</li> <li>• Hex Head</li> <li>• Square Head</li> </ul>	<ul style="list-style-type: none"> <li>• Allen Head</li> <li>• Hex Head</li> <li>• Square Head</li> </ul>	<ul style="list-style-type: none"> <li>• Allen Head</li> <li>• Hex Head</li> <li>• Square Head</li> </ul>
<b>6</b>	<b>CUTTING ANGLE</b>	<ul style="list-style-type: none"> <li>• 12°</li> <li>• 20°</li> </ul>	<ul style="list-style-type: none"> <li>• 12°</li> <li>• 20°</li> </ul>	<ul style="list-style-type: none"> <li>• 12°</li> <li>• 20°</li> </ul>
<b>7</b>	<b>SPINDLE DIAMETER*</b>	<ul style="list-style-type: none"> <li>• 1.813"</li> <li>• 50mm</li> <li>• 2.125"</li> </ul>	<ul style="list-style-type: none"> <li>• 1.813"</li> <li>• 50mm</li> <li>• 2.125"</li> </ul>	<ul style="list-style-type: none"> <li>• 1.813"</li> <li>• 50mm</li> <li>• 2.125"</li> </ul>
<i>Additional Options: *Heat Treated Sleeves for Keyed Spindles **Axial Constant Hubs</i>				

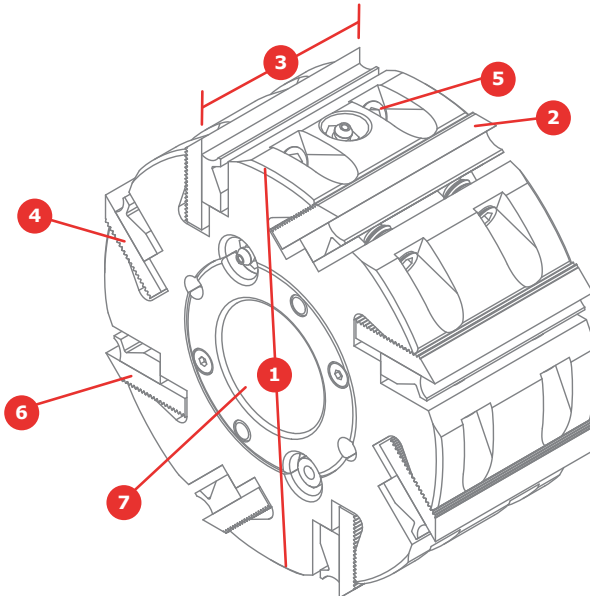

# SHEAR CUT ACE-LOC MOULDER HEADS

To order or request a quote, please specify the following:

1 BODY DIAMETER	150mm	163mm	195mm
2 BODY WIDTH/ NUMBER OF KNIVES	<ul style="list-style-type: none"> <li>• 60mm/6 Knife</li> <li>• 76mm/6 Knife</li> <li>• 100mm/6 Knife</li> <li>• 130mm/6 Knife</li> <li>• 150mm/4 Knife</li> </ul>	<ul style="list-style-type: none"> <li>• 60mm/8 Knife</li> <li>• 76mm/8 Knife</li> <li>• 100mm/8 Knife</li> <li>• 130mm/6 Knife</li> <li>• 150mm/6 Knife</li> </ul>	<ul style="list-style-type: none"> <li>• 60mm/10 Knife</li> <li>• 76mm/10 Knife</li> <li>• 100mm/8 Knife</li> <li>• 130mm/8 Knife</li> <li>• 150mm/8 Knife</li> </ul>
3 POCKET STYLE	<ul style="list-style-type: none"> <li>• Corrugated</li> <li>• Flatback</li> </ul>	<ul style="list-style-type: none"> <li>• Corrugated</li> <li>• Flatback</li> </ul>	<ul style="list-style-type: none"> <li>• Corrugated</li> <li>• Flatback</li> </ul>
4 GIB SCREWS	<ul style="list-style-type: none"> <li>• Allen Head</li> <li>• Hex Head</li> <li>• Square Head</li> </ul>	<ul style="list-style-type: none"> <li>• Allen Head</li> <li>• Hex Head</li> <li>• Square Head</li> </ul>	<ul style="list-style-type: none"> <li>• Allen Head</li> <li>• Hex Head</li> <li>• Square Head</li> </ul>
5 CUTTING ANGLE	<ul style="list-style-type: none"> <li>• 20°</li> </ul>	<ul style="list-style-type: none"> <li>• 20°</li> </ul>	<ul style="list-style-type: none"> <li>• 20°</li> </ul>
6 SHEAR ANGLE	<ul style="list-style-type: none"> <li>• 10°</li> </ul>	<ul style="list-style-type: none"> <li>• 10°</li> </ul>	<ul style="list-style-type: none"> <li>• 10°</li> </ul>
7 SPINDLE DIAMETER*	<ul style="list-style-type: none"> <li>• 1.813"</li> <li>• 50mm</li> <li>• 2.125"</li> </ul>	<ul style="list-style-type: none"> <li>• 1.813"</li> <li>• 50mm</li> <li>• 2.125"</li> </ul>	<ul style="list-style-type: none"> <li>• 1.813"</li> <li>• 50mm</li> <li>• 2.125"</li> </ul>
8 SHEAR DIRECTION	RIGHT or LEFT SHEAR		
9 SHEAR ROTATION	CW or CCW		

*Additional Options: \*Heat Treated Sleeves for Keyed Spindles \*\*Axial Constant Hubs*

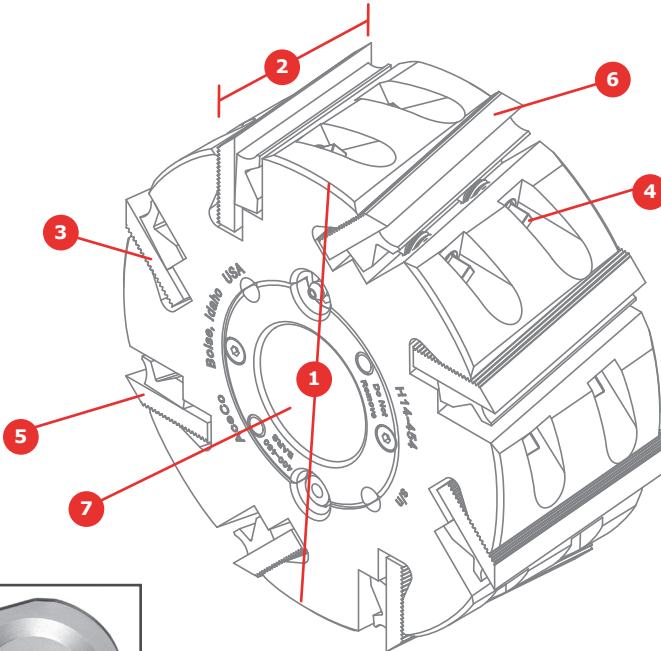

**SHEAR KNIFE SHARPENING GUIDE**  
 Required for sharpening and profiling shear heads.  
 Part # G12-006

# HSK MOULDER HEADS

To order or request a quote,  
please specify the following:

<b>1 BODY DIAMETER</b>	<ul style="list-style-type: none"> <li>• 90 mm</li> </ul>
<b>2 NUMBER OF KNIVES</b>	<ul style="list-style-type: none"> <li>• 2 Knife</li> <li>• 3 Knife</li> <li>• 4 Knife</li> </ul>
<b>3 CUTTING WIDTH</b>	<ul style="list-style-type: none"> <li>• 60mm</li> <li>• 80mm</li> <li>• 100mm</li> <li>• 130mm</li> <li>• 150mm</li> <li>• 170mm</li> <li>• 180mm</li> <li>• 210mm</li> </ul>
<b>4 POCKET STYLE</b>	<ul style="list-style-type: none"> <li>• Corrugated</li> <li>• 16-60</li> </ul>
<b>5 GIB SCREWS</b>	<ul style="list-style-type: none"> <li>• Allen Head</li> </ul>
<b>6 CUTTING ANGLE</b>	<ul style="list-style-type: none"> <li>• 12°</li> <li>• 20°</li> </ul>

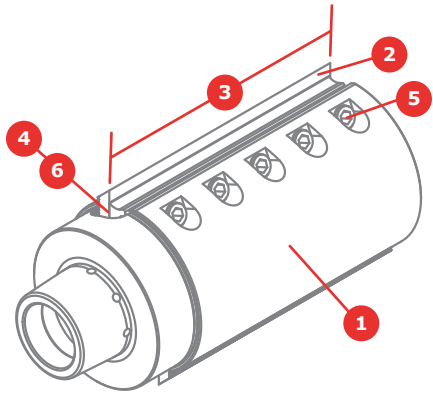

# STRAIGHT BORE MOULDER HEADS

To order or request a quote,  
please specify the following:

<b>1 BODY DIAMETER</b>	<ul style="list-style-type: none"> <li>• 122mm</li> <li>• 137mm</li> <li>• 150mm</li> </ul>
<b>2 NUMBER OF KNIVES</b>	<ul style="list-style-type: none"> <li>• 2 Knife</li> <li>• 4 Knife</li> <li>• 6 Knife</li> </ul>
<b>3 BODY WIDTH</b>	<ul style="list-style-type: none"> <li>• 40mm</li> <li>• 60mm</li> <li>• 76mm</li> <li>• 100mm</li> <li>• 130mm</li> <li>• 150mm</li> <li>• 180mm</li> <li>• 200mm</li> <li>• 230mm</li> <li>• 240mm</li> </ul>
<b>4 POCKET STYLE</b>	<ul style="list-style-type: none"> <li>• Corrugated</li> <li>• Flatback</li> </ul>
<b>5 GIB SCREWS</b>	<ul style="list-style-type: none"> <li>• Allen Head</li> <li>• Hex Head</li> <li>• Square</li> </ul>
<b>6 CUTTING ANGLE</b>	<ul style="list-style-type: none"> <li>• 12°</li> <li>• 20°</li> </ul>
<b>7 SPINDLE DIAMETER</b>	<ul style="list-style-type: none"> <li>• 1.500"</li> <li>• 40mm</li> <li>• 1.813"</li> <li>• 50mm</li> <li>• 2.125"</li> </ul>

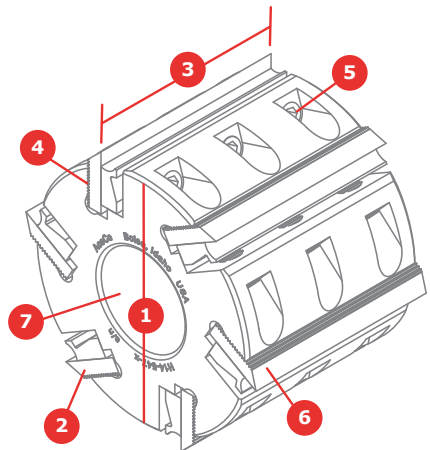

# PLANER TOOLS

ALCÉE  
BOISE, IDAHO

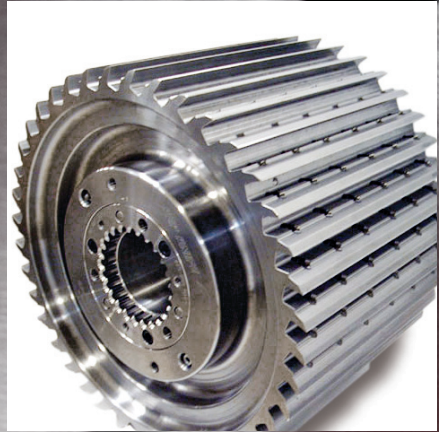

# PLANER HEAD

**HIGH TENSILE ALLOY STEEL**  
4150 Heat-treated steel for maximum durability and performance.

**GIB SCREWS**  
Allen head are standard - Square or Hex head are also available

**PLUNGER STYLE GREASE ZERKS**  
The plunger style is cleaner and more reliable than a check ball.

**HARDENED RADIUS GIBS**  
Heat-treated all the way through to resist screw wear; radius design provides better chip flow.

**CHOICE OF CUTTING ANGLES**

**7200 RPM BALANCING**  
Precision balanced on a computer-aided dynamic balancer to ISO Grade G-1.0, far beyond industry standards.

**HYDRAULIC CENTERING**  
*Ace-Loc* hydraulic sleeves ensure repeatability, accuracy, and balance.

**CHOICE OF POCKET STYLE**

- Straight Knife 16-60° Corrugated
- Straight Knife Flat Back (Smooth)
- L-V Type Knife 16-90° Corrugated
- L Type Knife 16-90° Corrugated
- Key Knife®

**CHOICE OF CENTERING**

- *Ace-Loc* Hydraulic
- Taper Bore

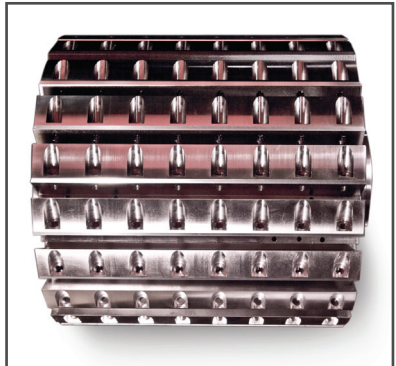
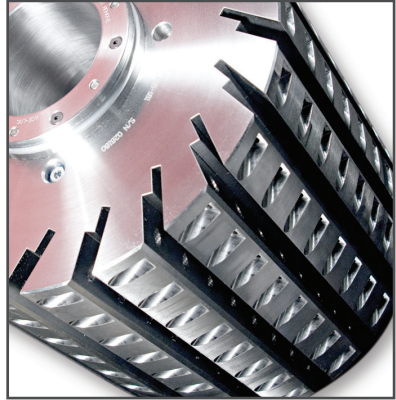

# STRAIGHT KNIFE PLANER HEADS

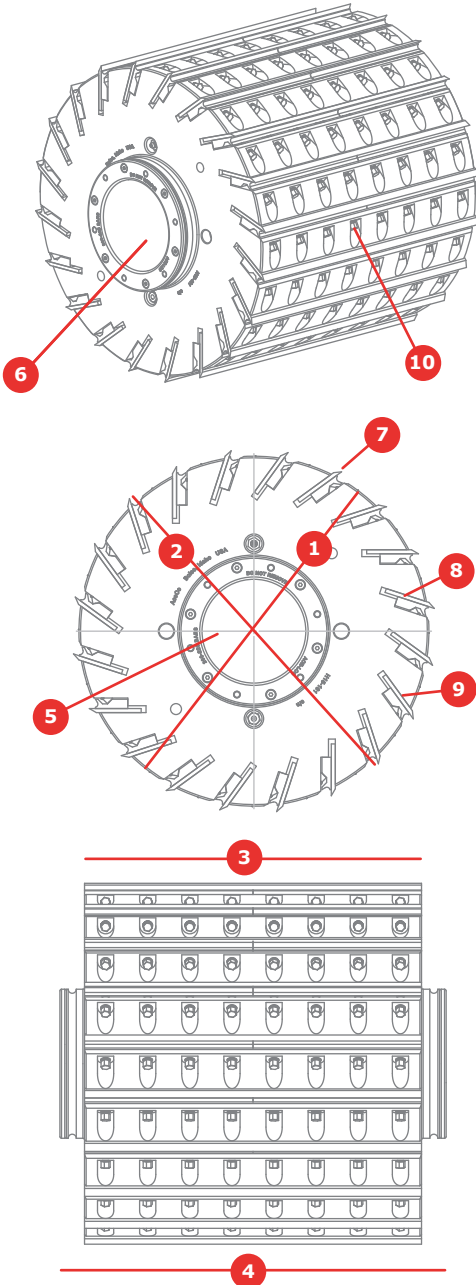

To order or request a quote,  
please specify the following:

1	<b>BODY DIAMETER</b>
2	<b>CUTTING CIRCLE</b> <ul style="list-style-type: none"> <li>Diameter across head from cutting tip to tip</li> </ul>
3	<b>CUTTING WIDTH</b>
4	<b>OVERALL BODY WIDTH</b>
5	<b>SPINDLE DIAMETER</b>
6	<b>CENTERING TYPE</b> <ul style="list-style-type: none"> <li>Ace-Loc Hydraulic</li> <li>Taper Bore</li> </ul>
7	<b>NUMBER OF KNIVES</b>
8	<b>KNIFE TYPE</b> <ul style="list-style-type: none"> <li>16-60° Corrugated</li> <li>Flat Back (Smooth)</li> <li>Key Knife®</li> </ul>
9	<b>CUTTING ANGLE</b>
10	<b>GIB SCREWS</b> <ul style="list-style-type: none"> <li>Hex Head</li> <li>Square Head</li> <li>Allen Head</li> </ul>
	<b>MACHINE INFORMATION</b> <ul style="list-style-type: none"> <li>Make /Model</li> <li>R.P.M.</li> <li>Feed Rate</li> </ul>

# “L” KNIFE PLANER HEADS

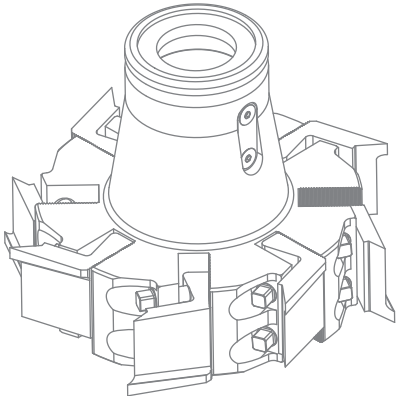
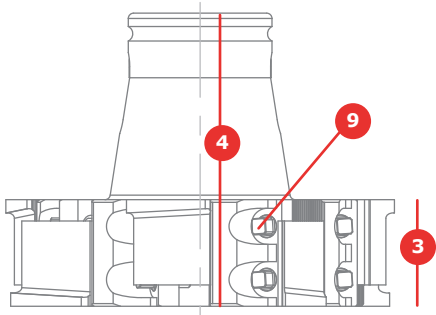
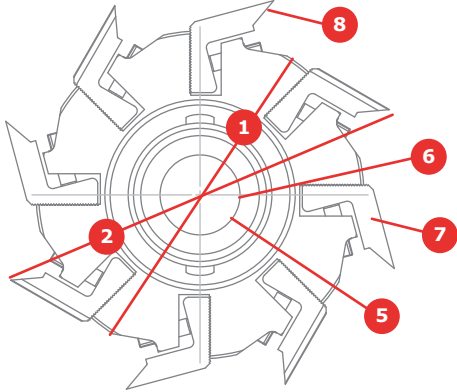

To order or request a quote, please specify the following:

1	<b>BODY DIAMETER</b>
2	<b>CUTTING CIRCLE</b> <ul style="list-style-type: none"> <li>Diameter across head from cutting tip to tip</li> </ul>
3	<b>CUTTING WIDTH</b>
4	<b>OVERALL BODY HEIGHT</b>
5	<b>SPINDLE DIAMETER / SPINDLE TAPER</b>
6	<b>CENTERING TYPE</b> <ul style="list-style-type: none"> <li>Ace-Loc Hydraulic</li> <li>Taper Bore</li> </ul>
7	<b>NUMBER OF KNIVES</b>
8	<b>CUTTING ANGLE</b>
9	<b>GIB SCREWS</b> <ul style="list-style-type: none"> <li>Hex Head</li> <li>Square Head</li> <li>Allen Head</li> </ul>
<b>MACHINE INFORMATION</b>	
<ul style="list-style-type: none"> <li>Make /Model</li> <li>R.P.M.</li> <li>Feed Rate</li> </ul>	

TAPER BORE HEAD SHOWN - HYDRAULICALLY-CENTERED “L” KNIFE HEADS ALSO AVAILABLE.

# “L - V” KNIFE PLANER HEADS

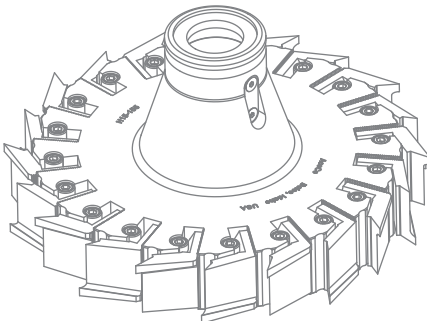
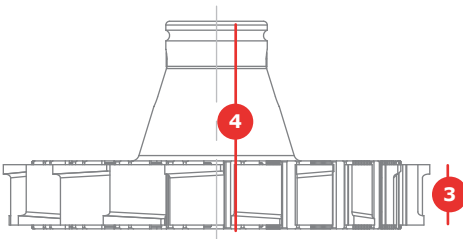
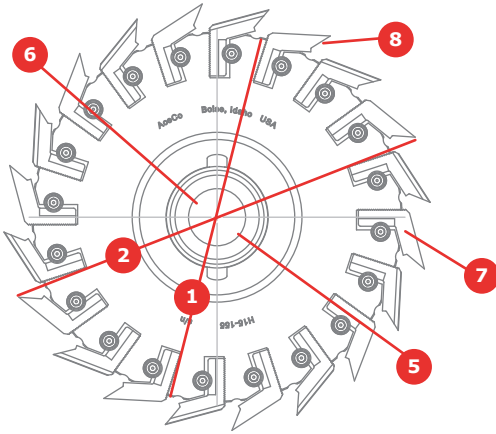

To order or request a quote, please specify the following:

<b>1</b>	<b>BODY DIAMETER</b>
<b>2</b>	<b>CUTTING CIRCLE</b> <ul style="list-style-type: none"> <li>Diameter across head from cutting tip to tip</li> </ul>
<b>3</b>	<b>CUTTING WIDTH</b>
<b>4</b>	<b>OVERALL BODY HEIGHT</b>
<b>5</b>	<b>SPINDLE DIAMETER / SPINDLE TAPER</b>
<b>6</b>	<b>CENTERING TYPE</b> <ul style="list-style-type: none"> <li>Ace-Loc Hydraulic</li> <li>Taper Bore</li> </ul>
<b>7</b>	<b>NUMBER OF KNIVES</b>
<b>8</b>	<b>CUTTING ANGLE</b>
<b>MACHINE INFORMATION</b> <ul style="list-style-type: none"> <li>Make /Model</li> <li>R.P.M.</li> <li>Feed Rate</li> </ul>	



“L” & “L-V” KNIVES



“L-V” KNIFE HOLDERS

TAPER BORE HEAD SHOWN - HYDRAULICALLY-CENTERED “L-V” KNIFE HEADS ALSO AVAILABLE.

# HYDRAULIC TOOL HOLDERS

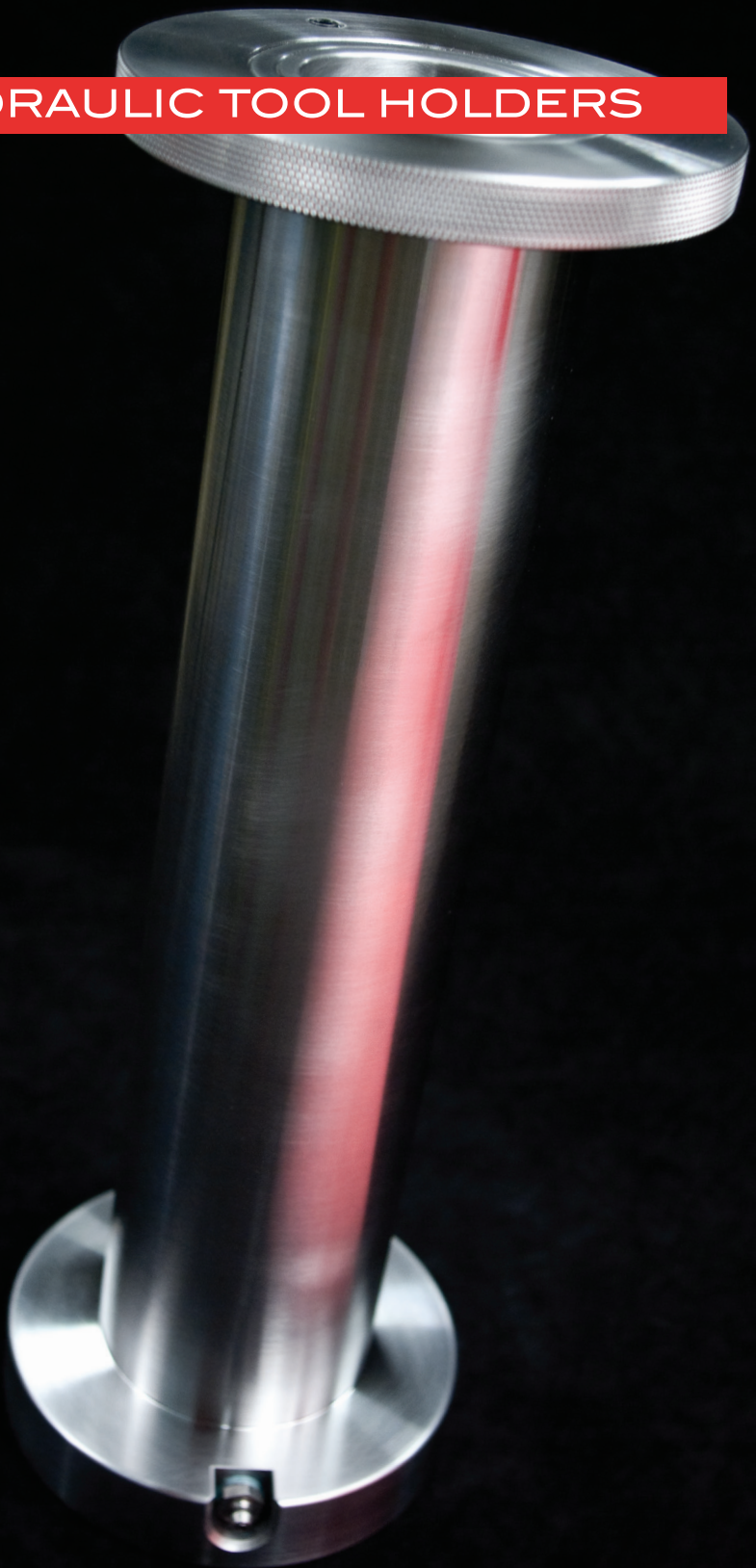

# ACE-LOC HYDRAULIC CARTRIDGES

Hydraulic cartridges are used where precision centering, quality finish, and maximum versatility are required. *Ace-Loc* cartridges are commonly used with wing-body tools, gang rip saw collars, and for upgrading straight bore cutter heads to hydraulic-centering.



**HIGH TENSILE ALLOY STEEL**  
4150 Heat-treated steel for maximum durability and performance.

**HYDRAULIC CENTERING**  
*Ace-Loc* hydraulic sleeves ensure repeatability, accuracy, and balance. Heat-treated sleeves are available for keyed spindles.

**7200 RPM BALANCING**  
Precision balanced on a computer-aided dynamic balancer to ISO Grade G -1.0, far beyond industry standards.

## CARTRIDGE TYPES

**B-Type** removable: Includes knurled ring nut.

**A-Type** Permanent: pressed in with no ring nut.

**PLUNGER STYLE GREASE ZERKS**  
The plunger style is cleaner and more reliable than a check ball.

To order or request a quote, please specify the following:

- |   |  |
|---|--|
| 1 | <b>SPINDLE DIAMETER</b>  |
| 2 | <b>CARTRIDGE DIAMETER</b>  |
| 3 | <b>CARTRIDGE TYPE</b> <ul style="list-style-type: none"> <li>• A-Type</li> <li>• B-Type</li> </ul> |
| 4 | <b>USABLE LENGTH</b>   |
| 5 | <b>OVERALL LENGTH</b>  |
| 6 | <b>FLANGE DIAMETER</b>   |
| 7 | <b>FLANGE THICKNESS</b>  |
| 8 | <b>BOLT CIRCLE</b>   |

## A-TYPE

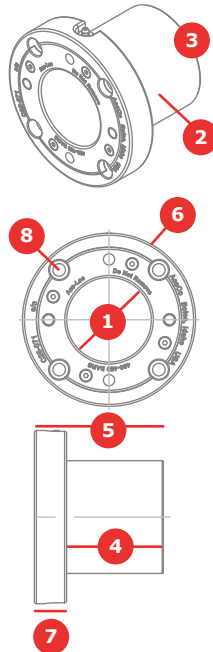

## B-TYPE

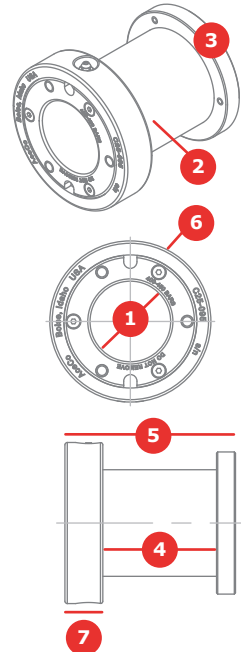

# HYDRAULIC SAW HOLDERS



# ACE-LOC HYDRAULIC SAW COLLARS

Hydraulically-centered saw collars for precision sawing applications. We can custom design collars to meet your exact requirements for many applications.

**HIGH TENSILE ALLOY STEEL**  
4150 Heat-treated steel for maximum durability and performance.

**HYDRAULIC CENTERING**  
Ace-Loc hydraulic sleeves ensure repeatability, accuracy, and balance. Heat-treated sleeves are available for keyed spindles.

**7200 RPM BALANCING**  
Precision balanced on a computer-aided dynamic balancer to ISO Grade G -1.0, far beyond industry standards.

**BLADE OPTIONS**  
Can be used for a single saw blade or multiple blade configurations.

**PLUNGER STYLE GREASE ZERKS**  
The plunger style is cleaner and more reliable than a check ball.



To order or request a quote, please specify the following:

<b>1</b>	<b>SPINDLE DIAMETER</b>
<b>2</b>	<b>COLLAR DIAMETER / SAW BLADE I.D.</b>
<b>3</b>	<b>USABLE WIDTH / SAW BLADE THICKNESS</b>
<b>4</b>	<b>SAW BLADE O.D. / CUTTING CIRCLE</b>
<b>5</b>	<b>OVERALL LENGTH</b>
<b>6</b>	<b>FLANGE DIAMETER</b>
<b>7</b>	<b>FLANGE THICKNESS</b>
<b>8</b>	<b>CLAMPING METHOD:</b> • Spanner Nut • Clamping Plate (as shown)

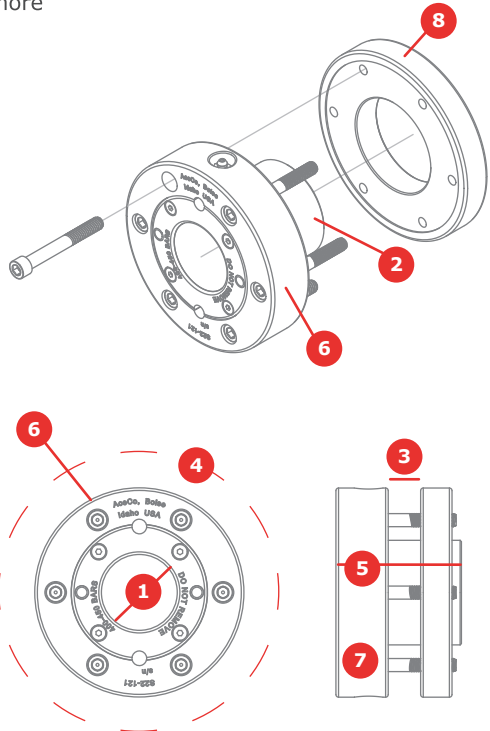

# ACCESSORIES

## FINGER JOINT



SAFETY LOCK COLLARS



MULTI-POST SETUP STANDS



SINGLE-POST SETUP STANDS



HOOK GAUGES

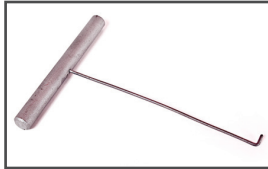

PULL-UP TOOL

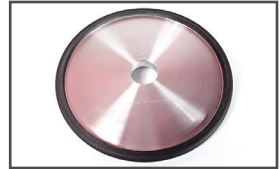

CBN GRINDING WHEELS

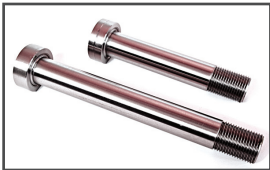

FJ BOLTS

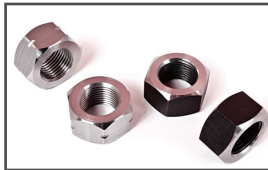

FJ NUTS



FJ WASHERS

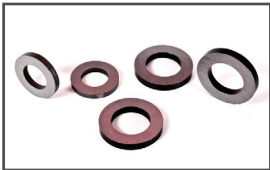

HARDENED INDEX SPACERS



DOG BONE SPACERS



MAST-LOCK SPACERS



30 TO 250 LB.  
TORQUE WRENCH



TORQUE SOCKET



DISC STYLE SPACERS



BRASS HEAD CLEANERS



TECHNICHEM  
CLEAR LUBE



TECHNICHEM  
BLADE CLEAN

# ACCESSORIES

## MOULDER / PLANER



**MOULDER SAFETY  
LOCK COLLARS**

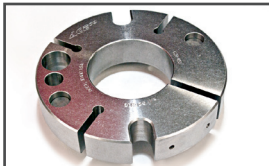

**PLANER SAFETY  
LOCK COLLAR**

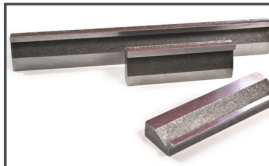

**HARDENED STEEL GIBS**



**ALLEN HEAD  
GIB SCREWS**



**HEX HEAD  
GIB SCREWS**



**SQUARE HEAD  
GIB SCREWS**



**5 TO 75 LB.  
TORQUE WRENCH**



**TORQUE SOCKET &  
EXTENSIONS**



**HYDRAULIC SLEEVES &  
O-RINGS**

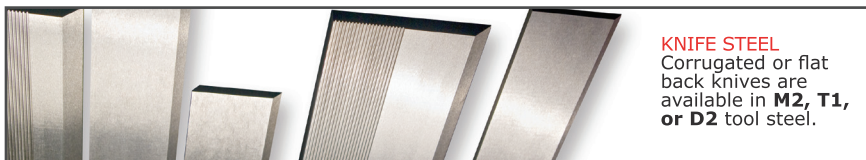

**KNIFE STEEL**  
Corrugated or flat  
back knives are  
available in **M2, T1,**  
or **D2** tool steel.

## HYDRAULIC FITTINGS / GREASE GUNS



**PRESSURE RELIEF VALVES**  
Part# GFS1/8NPTR



**GREASE ZERKS**  
Part# GFS1/8NPTZ



**ZERK & RELIEF  
VALVE SOCKET**



**HIGH PRESSURE  
GREASE GUN**



**METRIC PRESSURE RELIEF  
VALVES** Part# GFSM10R



**METRIC GREASE ZERKS**  
Part# GFSM10Z

# CUSTOM TOOLS

Every product in this catalog was a custom tool at one point in time. Many products have evolved to become standard parts within the industry while others remain custom for one particular customer. With industry experience, engineering and machinery technology, AceCo has the capability to create custom tooling solutions.

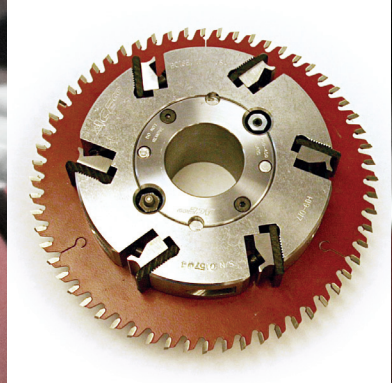

## ACECO GUARANTEE

All of our products are guaranteed against defects in material and workmanship under normal use and service for a period of one year from the date of purchase. AceCo Precision Manufacturing also guarantees our products to meet standards and tolerances as noted or specified per customer order. This warranty applies to all AceCo products when used in a normal industrial environment. Any tampering, misuse, or neglect will make this warranty null and void. AceCo's liability under this warranty is limited to repair of the product and/or replacement of parts and is given to purchasers in lieu of all other remedies, including incidental and consequential damages. There are no express warranties other than those specified herein. There are no warranties that extend beyond the description on the face hereof. No warranties, including but not limited to warranty of merchantability, shall be implied. AceCo will obligate itself only for normal freight charges in cases of prepaid warranty shipments; special freight rates are not included.

**F.O.B. Point:** All shipments are F.O.B. Boise, Idaho USA unless quoted otherwise.

**Terms of Payment:** Net 30 days. A service charge of 1.5% per month (18% per annum) applied to unpaid amount of any accounts 30 days past due.

**Discounts:** Quantity discounts are available upon request.

**Prices:** Prices are quoted in U.S. dollars and subject to change without notice.

**Specifications:** Product specifications are subject to change without notice.

**Delivery:** AceCo maintains an inventory level on many items displayed in this catalog. Contact the factory for a delivery date on custom tooling and high volume requirements.

## TECHNICAL SUPPORT

Visit [Aceco.com](http://Aceco.com) for all technical information, maintenance recommendations and trouble shooting issues. Downloads cover all aspects of AceCo tools:

- **Finger Joint Tooling**
- **Moulder Tooling**
- **Planer Tooling**
- **Assembly & Set-up Instructions**
- **Torque Specifications**
- **Grinding Procedures**
- **Operating Conditions: Feeds and Speeds**
- **Hydraulic Centering**
- **Balancing**

Our technical staff is available to answer any questions about our tooling and uses.



ACECO PRECISION TOOLS  
4419 FEDERAL WAY  
BOISE, IDAHO 83716  
USA

PH: 208-343-7712  
INFO@ACECO.COM  
WWW.ACECO.COM/WOODTOOL

MADE IN USA